

LED Driver

1600HTHxxxCVG-xC-yyy

V0.6

2026/4/9

Powerland Signatures						
Prepared	Checked			Approved	Marketing	CPO
	Mechanical Engineer	Safety Engineer	R&D Manager			

Please return us one copy of the document with your approval signature.

请客户确认签字后回传我司此规格承认书。

Powerland Technology Inc.

南京博兰得电子科技有限公司

Building 9, No. 1 Zidan Rd., Qinhuai Dist., Nanjing, China

南京市秦淮区紫丹路设计产业园 9 号楼

Email: sales@powerlandtech.com Phone: +86-25-85582306

**1600HTHxxxCVG-xC 1600W AC/DC Constant Current LED Driver
with Optimized Multi-Channel Power Distribution**

Features

- Multi-channel constant current output with a total output power of 1600W
- High efficiency: 95% typical @400 VAC, full load
- Ultra low THD at light load
- Dimming port programming with driver power on
- Optional UART Based Communication Protocol or RS485 Protocol Digital Dimming or DMX Dimming
- DMX512-RDM Control up to 40 fps
- Optimized Multi-channel Power Distribution

Description

1600W LED Drivers offers digital programmable drivers with wide-range adjustable output current, together with 12V/200mA auxiliary output for smart lighting.

Model Name Definition

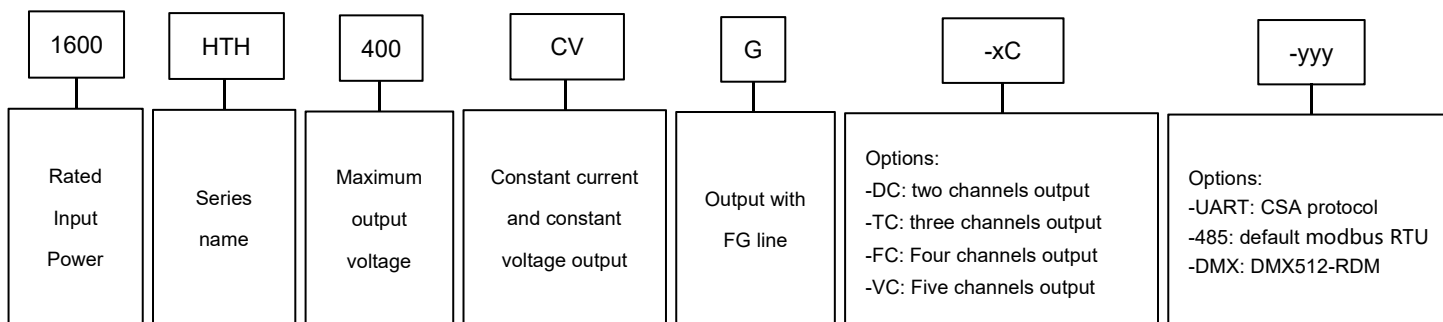

Specifications

Part Number	Channels	PO_MAX (W)	IO_RANGE @ CC (A)	VO_RANGE (V)	Typical η (%) @ 400 VAC
1600HTH320CVG-DC	1	1400	2.35-5.88	240-320	95
	2	300	0.4-2	50-150	
1600HTH320CVG-TC	1	1400	2.35-5.88	240-320	95
	2, 3	300	0.4-2	50-150	
1600HTH320CVG-FC	1	1400	2.35-5.88	240-320	95
	2, 3, 4	300	0.4-2	50-150	
1600HTH320CVG-VC	1	1400	2.35-5.88	240-320	95
	2, 3, 4	300	0.4-2	50-150	
	5	100	0.2-0.75A	50-150	

1600HTH400CVG-DC	1	1400	1.88-4.7	300-400	95
	2	300	0.2-2	50-200	
1600HTH400CVG-TC	1	1400	1.88-4.7	300-400	95
	2, 3	300	0.4-2	50-200	
1600HTH400CVG-FC	1	1400	1.88-4.7	300-400	95
	2, 3, 4	300	0.4-2	50-200	
1600HTH400CVG-VC	1	1400	1.88-4.7	300-400	95
	2, 3, 4	300	0.4-2	50-200	
	5	100	0.2-0.75A	50-200	

Note: The total power of all channels shall not exceed 1600 W, refer to Operation Range Curve and Operation principle of multi-channel optimized power distribution for the details.

These protocols of different communication interfaces can be obtained from sales.

Table of Contents

1. Input Specifications	2
2. Output Specifications	2
3. General Specifications	3
4. Dimming Specifications	3
4.1. DMX Dimming for the DMX model	3
4.2. RDM Protocol for the DMX model	3
4.3. Other Protocol	4
5. Isolation	4
6. Safety & EMC Compliance	4
7. Performance Curve	5
7.1. Inrush Current Curve	5
Figure 1. Inrush Current @ full load and cold start	5
7.2. Derating Curve	6
Figure 2. Input Voltage Derating Curve	6
7.3. Lifetime Curve	6
Figure 3. Life vs Case Temperature	6
7.4. Operation Range Curve	6
Figure 4. I/V Operating Area for CH1 (1600HTH400CV)	6
Figure 5. I/V Operating Area for CH1 (1600HTH320CV)	6
Figure 6. I/V Operating Area for CH2,CH3,CH4 (1600HTH400CV)	7
Figure 7. I/V Operating Area for CH2,CH3,CH4 (1600HTH320CV)	7
Figure 8. I/V Operating Area for CH5 (1600HTH400CV)	7
Figure 9. I/V Operating Area for CH5 (1600HTH320CV)	7
7.5. General Performance Curve	7
Figure 10. Total Harmonics vs Different Loads for CH1(1600HTH400CV)	7
Figure 11. Efficiency vs Different Loads for CH1 (1600HTH400CV)	7
Figure 12. Power Factor vs Different Loads for CH1 (1600HTH400CV)	8
Figure 13. Total Harmonics vs Different Loads for CH1,CH2,CH3,CH4,CH5(1600HTH400CV)	8
Figure 14. Efficiency vs Different Loads for CH1,CH2,CH3,CH4,CH5(1600HTH400CV)	8
Figure 15. Power Factor vs Different Loads for CH1,CH2,CH3,CH4,CH5(1600HTH400CV)	8
8. Application Information	8
8.1. Operation principle of multi-channel optimized power distribution	8
Figure 16. The Block Diagram of Automatic Power Distribution for a 5-channel LED Driver	9
8.2. Programming	10
Figure 17. Programming Wiring	10
9. Mechanical Specification	11
Figure 18. Mechanical Drawing	11
10. Ordering information	11
11. Revision History	12

1. Input Specifications

	Parameter	Min.	Typ.	Max.	Unit	Notes
V_{IN_AC}	Rated Input AC Voltage	208	-	480	VAC	The upper limit voltage of CE certification:400 VAC
V_{IN_RANGE}	Input AC Voltage Range	187	-	528	VAC	
F_{LINE}	Input Frequency	47	-	63	Hz	
I_{LKG}	Leakage Current	-	-	0.75	mA	At 480 VAC/ 60 Hz input , grounding effectively
I_{IN_AC}	Input AC Current	-	-	3.9	A	Measured at 25°C, full load and 480 VAC input.
		-	-	6.7	A	Measured at 25°C, full load and 277 VAC input.
I_{PK_INRUSH}	Inrush Peak Current	-	-	35	A	At 400 VAC input, 25°C cold start. See Inrush Current Waveform for the details.
PF	Power Factor	0.9	-	-		At 208-480 VAC, full load, 25°C and 50 Hz
THD	Total Harmonic	-	-	20	%	
η	Efficiency	94	95	-	%	Measured at 400 VAC input, 100% load and steady-state temperature in 25°C ambient

2. Output Specifications

	Parameter	Min.	Typ.	Max.	Unit	Notes
I_{O_ACCU}	Output Current Accuracy relative to I_o set	-5	-	5	%	At 25°C and full load condition. Can contact sales ask for better current tolerance.
I_{O_RIPPLE}	Total Output Current Ripple (pk-pk) relative to I_o max	-	-	10	%	At 25°C and full load condition, 8 kHz BW
$I_{O_OVERSHOOT}$	Startup Overshoot Current relative to I_o max	-	-	20	%	At 25°C and full load condition, 8 kHz BW
V_{O_OCV}	No Load Output Voltage	-	340	350	V	1600HTH320CV
		-	-	440	V	1600HTH400CV
V_{O_LINE}	Line Regulation	-	-	± 3	%	Measured at 25°C and full load
V_{O_LOAD}	Load Regulation	-	-	± 3	%	At 25°C condition
T_{ON_DELAY}	Turn-on Delay Time	-	0.8	1.5	s	Measured at 277 VAC input.
I_{O_TC}	Temperature Coefficient of I_o set	-0.03	-	0.03	%/°C	Case temperature = 0°C ~Tc max
V_{O_AUX}	12V Auxiliary Output Voltage	11	12	15	V	
I_{O_AUX}	12V Auxiliary Output Current	0	-	200	mA	Return terminal is "Dim-"
T_{OTP}	Over Temperature Protection Threshold	90	-	100	°C	Output current will drop or shut down.

SCP	Short Circuit Protection Threshold					Auxiliary source: Hiccup mode, Auto recover Main output: Locked or auto recover
OCP	Over Current Protection Threshold					Locked or auto recover

3. General Specifications

	Parameter	Min.	Typ.	Max.	Unit	Notes
$P_{STANDBY}$	Standby power	-	-	2	W	Measured at 277 VAC/60 Hz; Dimming off
T_{MTBF}	Mean Time Between Failure	234,000	-	-	Hours	Measured at 277 VAC input, 80% load and 25°C ambient temperature (MIL-HDBK-217F)
$T_{LIFETIME}$	Lifetime	50,000	-	-	Hours	Measured at 480 VAC input, 100% load and 75°C case temperature; See lifetime vs T_c curve for the details
T_c	Operating Case Temperature T_c	-40	-	90	°C	Under harsh conditions, when $t_c > 85^\circ\text{C}$, it may trigger automatic derating to around 80%.
T_A	Operating Ambient Temperature T_a	-40	-	50	°C	
T_{STG}	Storage Temperature	-40	-	85	°C	Humidity: 5%RH to 95%RH
	IP Grade	IP66				
	Dimensions L × W × H	19.75 × 4.06 × 2.04			inch	
		501.6 × 103 × 51.8			mm	
	Net Weight	-	6.01	-	kg	

4. Dimming Specifications

4.1. DMX Dimming for the DMX model

Parameter	Min.	Typ.	Max.	Unit	Notes
DMX+ to DMX-	-5	-	7	V	
DMX+ to the case of the drive	22	-	-	MΩ	
DMX- to the case of the drive	22	-	-	MΩ	
Input Logic 0	-	-	-0.2	V	DMX+ to DMX-
Input Logic 1	0.2	-	-	V	DMX+ to DMX-
Communication Baud Rate	-	250	-	K bps	
Dimming Output Range relative to I_o max	2	-	100	%	

4.2. RDM Protocol for the DMX model

The RDM protocol is a bidirectional communication protocol based on the standard DMX512 protocol, which allows users to Configure, monitor, and query remote devices. The RDM protocol adds control to the DMX signal by adding control Information packets are used to achieve communication with devices.

The following are the registers supported by the RDM Protocol:

No	Address	Param	Value	R/W
Network Management(default)				
1	0x0001	DISC_UNIQUE_BRANCH		
2	0x0002	DISC_MUTE		
3	0x0003	DISC_UN_MUTE		
RDM Information(default)				
1	0x0050	SUPPORTED_PARAMETERS		R
2	0x0051	PARAMETER_DESCRIPTION		R
3	0x0060	DEVICE_INFO		R
4	0x00C0	SOFTWARE_VERSION_LABEL		R
5	0x00F0	DMX_START_ADDRESS		R/W
6	0x1000	IDENTIFY_DEVICE		R/W
RDM Information				
1	0x0080	DEVICE_MODEL_DESCRIPTION		R
2	0x0081	MANUFACTURER_LABEL	POWERLAND	R
3	0x0082	DEVICE_LABEL		R/W
4	0x00E0	DMX_PERSONALITY		R/W
5	0x0120	SLOT_INFO		R
6	0x0121	SLOT_DESCRIPTION		R
7	0x0200	SENSOR_DEFINITION	Voltage,Current,Temp	R
8	0x0201	SENSOR_VALUE		R
9	0x0400	DEVICE_HOURS		R
10	0x0403	LAMP_STATE		R
11	0x0405	DEVICE_POWER_CYCLES		R

4.3.Other Protocol

Please contact us for UART and RS485 dimming protocol.

5.Isolation

Isolation	AC Input	DC Output	Dimming (SELV)	Housing
AC Input	/	Double isolation	Double isolation	Basic
DC Output	Double isolation	/	Basic	Basic
Dimming	Double isolation	Basic	/	Basic
Housing	Basic	Basic	Basic	/

6.Safety & EMC Compliance

Safety Category	Standard
Dielectric Strength(Hi-pot)	Primary to Output: 3600 VAC 10mA max (1600HTH320CV) 3760 VAC 10mA max (1600HTH400CV).
	Primary to Dimming: 3600 VAC 10mA max (1600HTH320CV) 3760 VAC 10mA max (1600HTH400CV).
	Primary to Earth: 1960 VAC 10mA max.

	Output to Earth: 1700 VAC 10mA max(1600HTH320CV) 1880 VAC 10mA max(1600HTH400CV).
	Dimming to Output: 1700 VAC 10mA max(1600HTH320CV) 1880 VAC 10mA max(1600HTH400CV).
Insulation Resistance	50Mohm min.@ primary to secondary add 500Vdc test voltage
Grounded Resistance	0.1Ω max. @ 25A, 1 minute
EMI Standards	Notes
EN55015	ANSI C63.4:2009 Class B
	This device complies with Part 15 of the FCC Rules. Operation is subject to the following two conditions: (1) this device may not cause harmful interference, and (2) this device must accept any interference received, including interference that may cause undesired Operation.
EMS Standards	Notes
EN 61000-4-2	Electrostatic Discharge (ESD): 8 kV air discharge, 4 kV contact discharge, criteria A
EN 61000-4-3	Radio-Frequency Electromagnetic Field Susceptibility Test-RS, criteria A
EN 61000-4-4	Electrical Fast Transient / Burst-EFT: level 3, criteria B
EN 61000-4-5	Surge Immunity Test: AC Power Line: line to line 4 kV, line to earth 6 kV, criteria B
EN 61000-4-6	Conducted Radio Frequency Disturbances Test-CS, criteria A
EN 61000-4-8	Power Frequency Magnetic Field Test, criteria A
EN 61000-4-11	Voltage Dips, criteria B
EN IEC 61547	Electromagnetic Immunity Requirements Applies To Lighting Equipment

Note1:This LED driver meets the EMI specifications above, but EMI performance of a luminaire that contains it depends also on the other devices connected to the driver and on the fixture itself.

7.Performance Curve

7.1.Inrush Current Curve

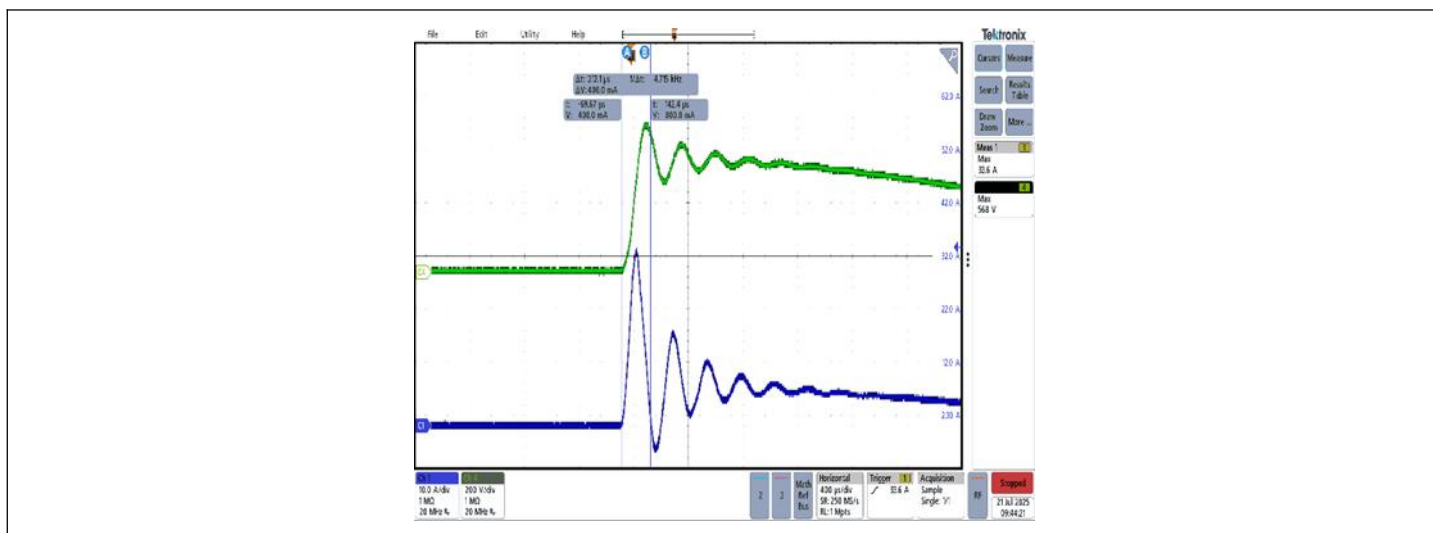

Figure 1.Inrush Current @ full load and cold start

Vin (VAC)	F _{LINE} (Hz)	I _{PK_INRUSH} (A)	T _{DURATION} (μs)
400	50	33.6	212.1

7.2. Derating Curve

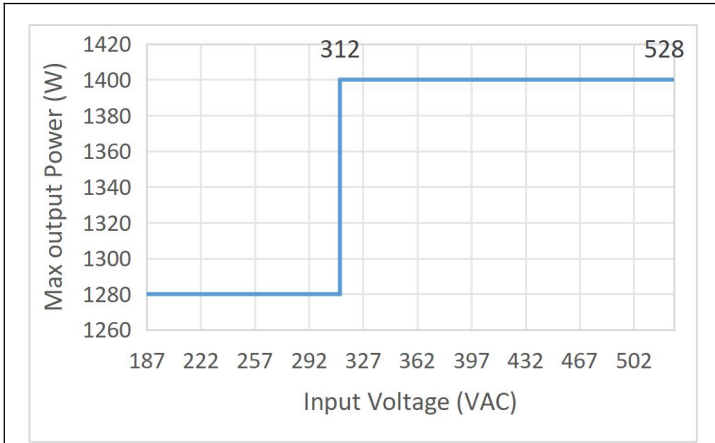

Figure 2. Input Voltage Derating Curve

7.3. Lifetime Curve

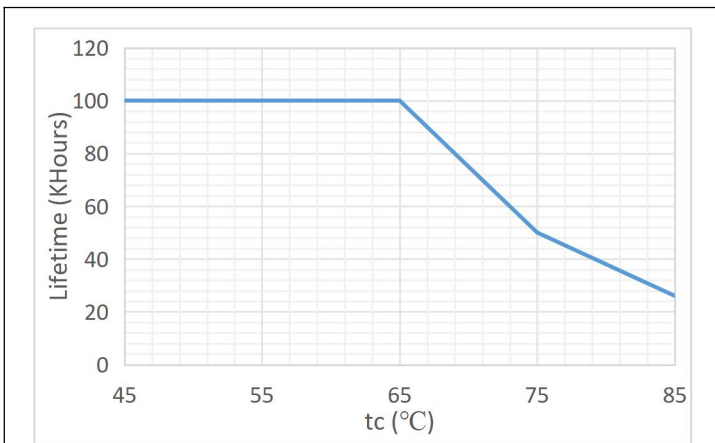

Figure 3. Life vs Case Temperature

7.4. Operation Range Curve

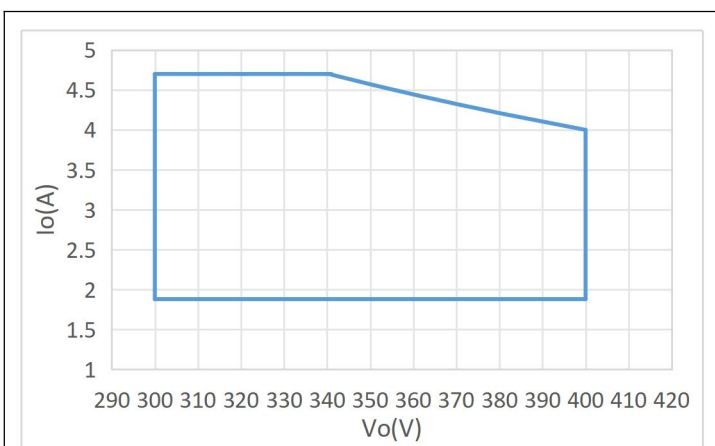

Figure 4. I/V Operating Area for CH1 (1600HTH400CV)

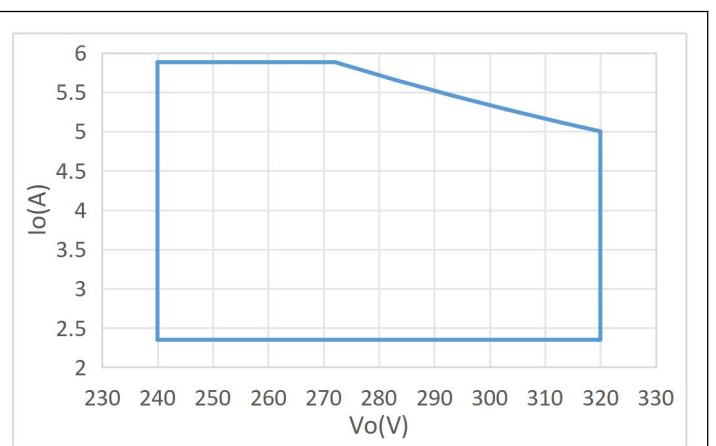

Figure 5. I/V Operating Area for CH1 (1600HTH320CV)

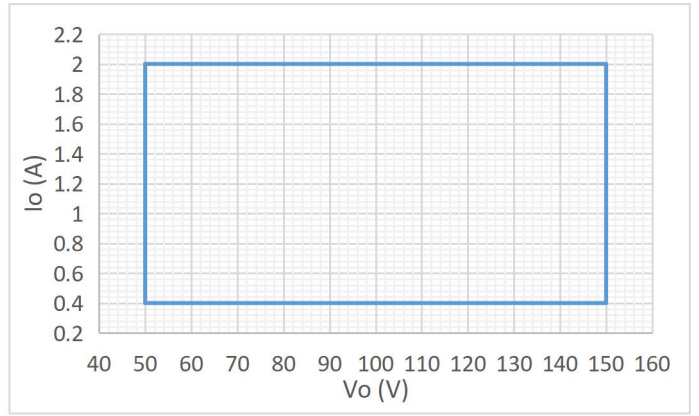
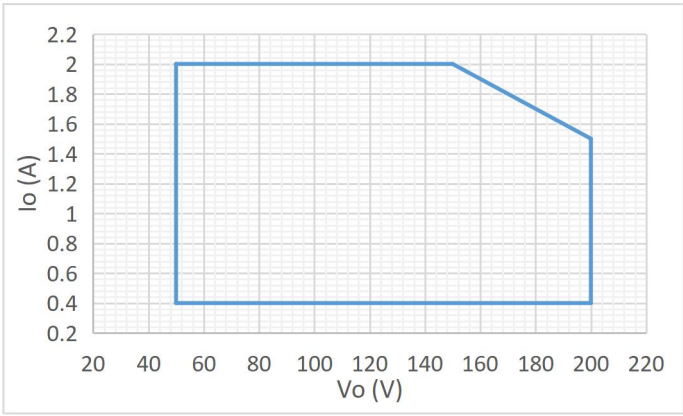

Figure 6. I/V Operating Area for CH2, CH3, CH4 (1600HTH400CV)

Figure 7. I/V Operating Area for CH2, CH3, CH4 (1600HTH320CV)

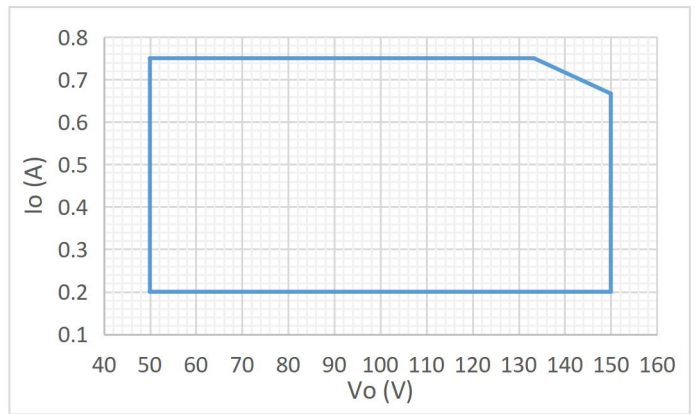
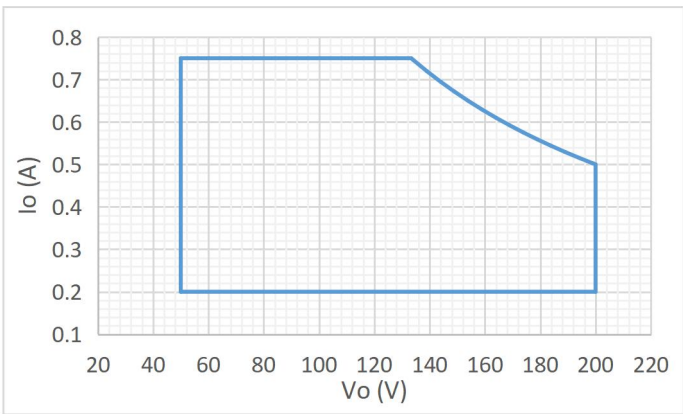

Figure 8. I/V Operating Area for CH5 (1600HTH400CV)

Figure 9. I/V Operating Area for CH5 (1600HTH320CV)

7.5. General Performance Curve

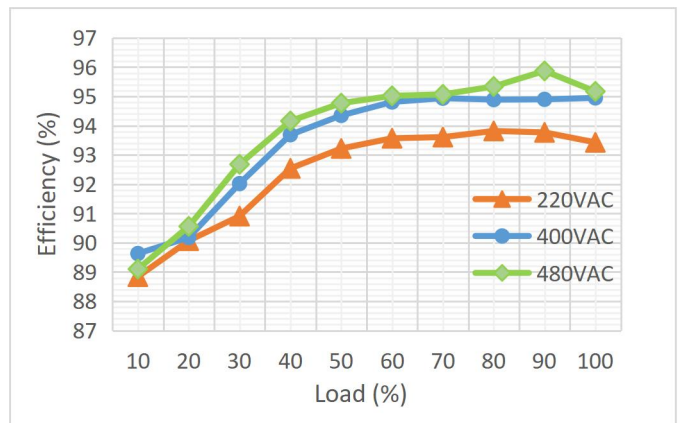
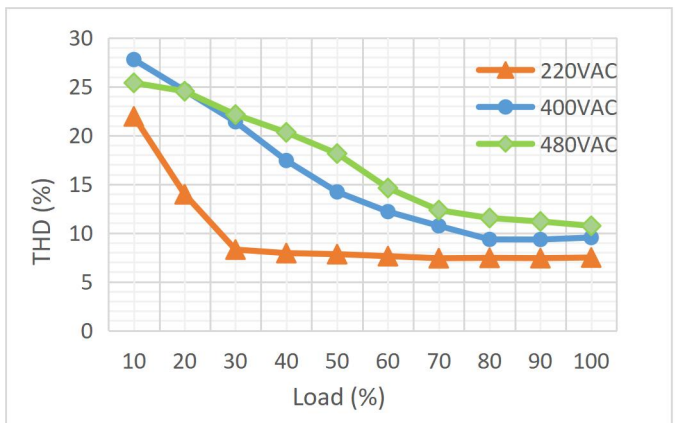

Figure 10. Total Harmonics vs Different Loads for CH1(1600HTH400CV)

Figure 11. Efficiency vs Different Loads for CH1 (1600HTH400CV)

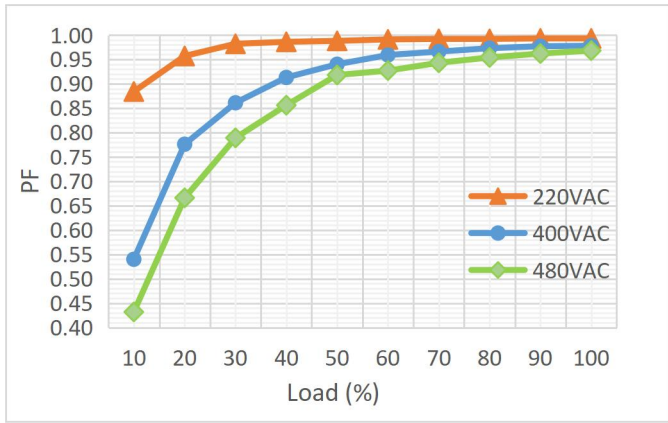

Figure 12. Power Factor vs Different Loads for CH1 (1600HTH400CV)

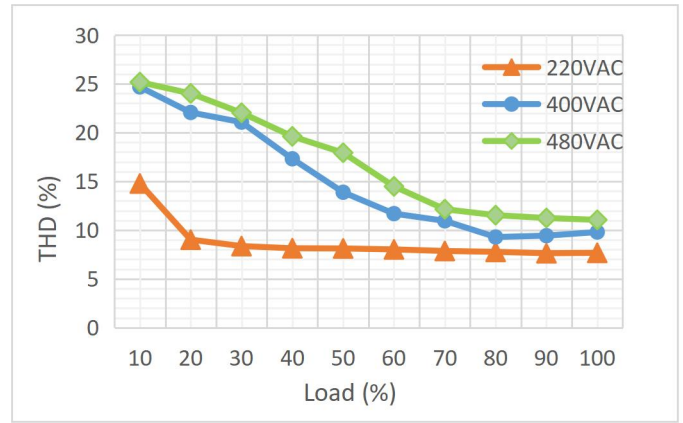

Figure 13. Total Harmonics vs Different Loads for CH1, CH2, CH3, CH4, CH5 (1600HTH400CV)

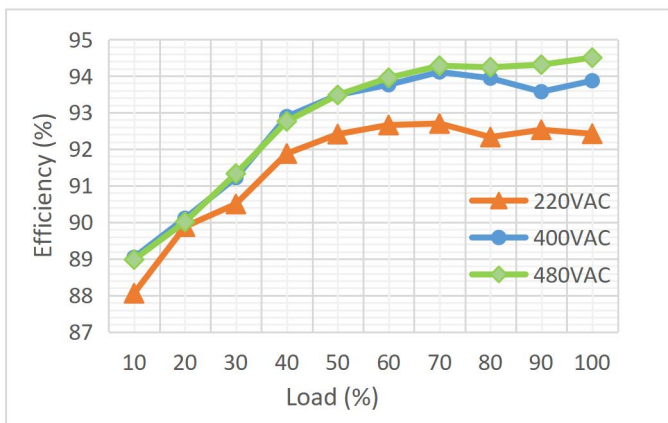

Figure 14. Efficiency vs Different Loads for CH1, CH2, CH3, CH4, CH5 (1600HTH400CV)

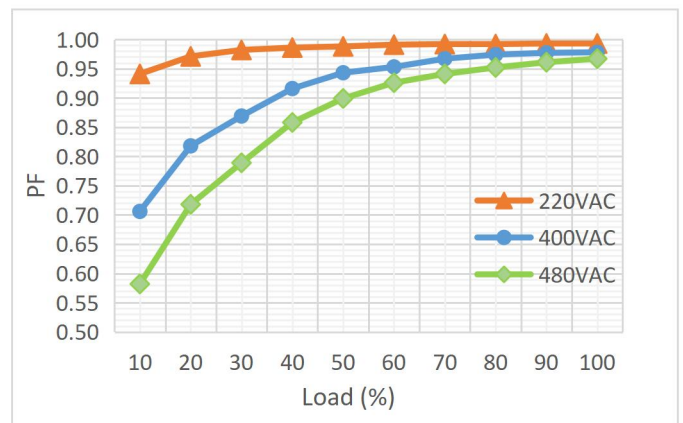

Figure 15. Power Factor vs Different Loads for CH1, CH2, CH3, CH4, CH5 (1600HTH400CV)

8. Application Information

8.1. Operation principle of multi-channel optimized power distribution

The following figure shows the block diagram of the automatic power distribution feature of the multi-channel AC/DC LED driver. Taking a 5-channel driver as an example, there are four buck converters taking the output of the main converter as the input. Therefore, V_{o2} , V_{o3} , V_{o4} and V_{o5} are lower than V_{o1} . The maximum actual power of the driver, P_{max} , is configured via P_{max_Config} as a percentage of the LED driver's maximum rated power, the default value of P_{max} is 1600W. The available maximum power can be shared among all channels or delivered to Channel 1 only when all other channels are turned off. This automatic power distribution feature optimizes overall hardware utilization.

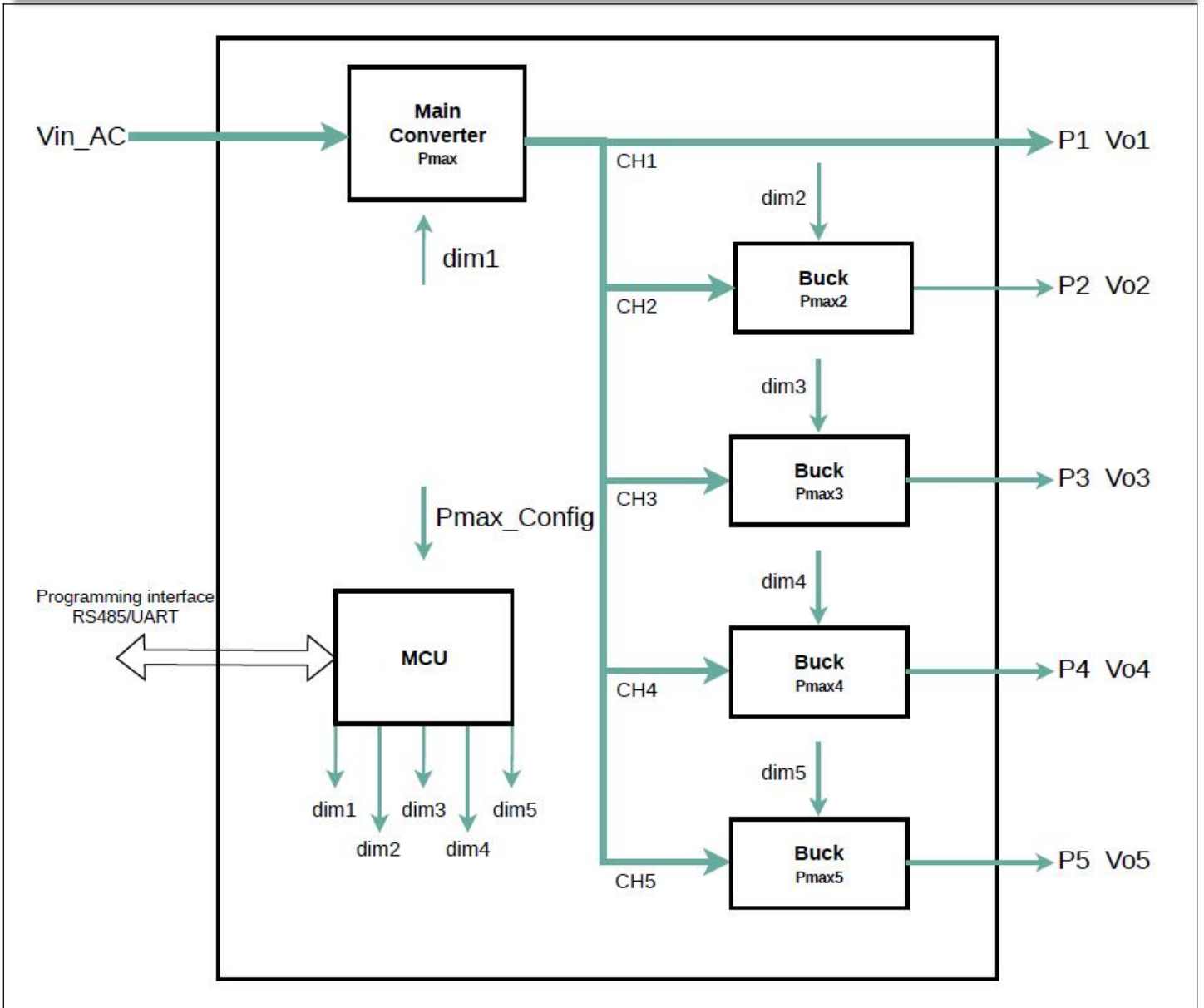

Figure 16.The Block Diagram of Automatic Power Distribution for a 5-channel LED Driver

The power delivered to Channel 1 is defined by the lower $P1$ value of Equitation (1) and (2):

$$P1 = Pmax - (Pmax2 \cdot dim2 + Pmax3 \cdot dim3 + Pmax4 \cdot dim4 + Pmax5 \cdot dim5) \tag{1}$$

$$P1 = Pmax \cdot dim1 \tag{2}$$

Where the $Pmax$ is the maximum actual power available shared by all channels; the $dim1, dim2, dim3, dim4, dim5$ are the dimming factors, the percentage ratios of the desired output current over the configured output current for each of the respective converter. Equation (1) also shows that Channel 2, 3, 4 and 5 have higher priorities than Channel 1. After supplying $P2, P3, P4,$ and $P5$, the remaining power will be delivered to Channel 1. When there is no power delivery for $P2, P3, P4$ and $P5$, the maximum output power of $P1$ can be as high as $Pmax$.

As we can find from the analysis, the converter achieves the controlled thermal and reliable operation by the active control of the maximum power delivered. The power sharing scheme optimize

8.2.Programming

- Programmer:Supro3.0
- Software:Supro3.0

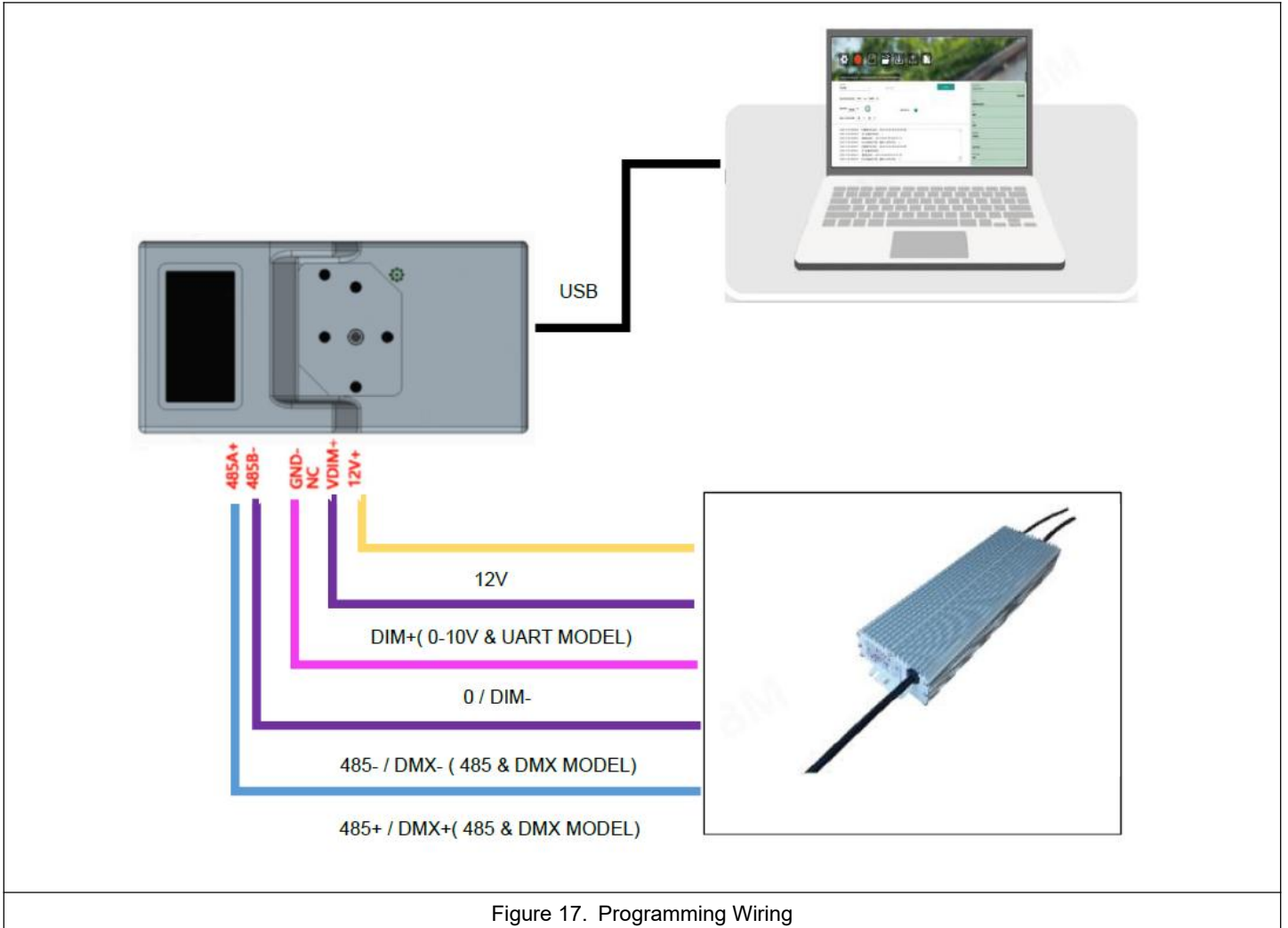

Figure 17. Programming Wiring

Note2:Please download related documents on the website or ask sales for help.

Website like:https://led.powerlandtech.com/product_new/Other.

9. Mechanical Specification

Take 1600HTH320CVG-VC-485 as a example:

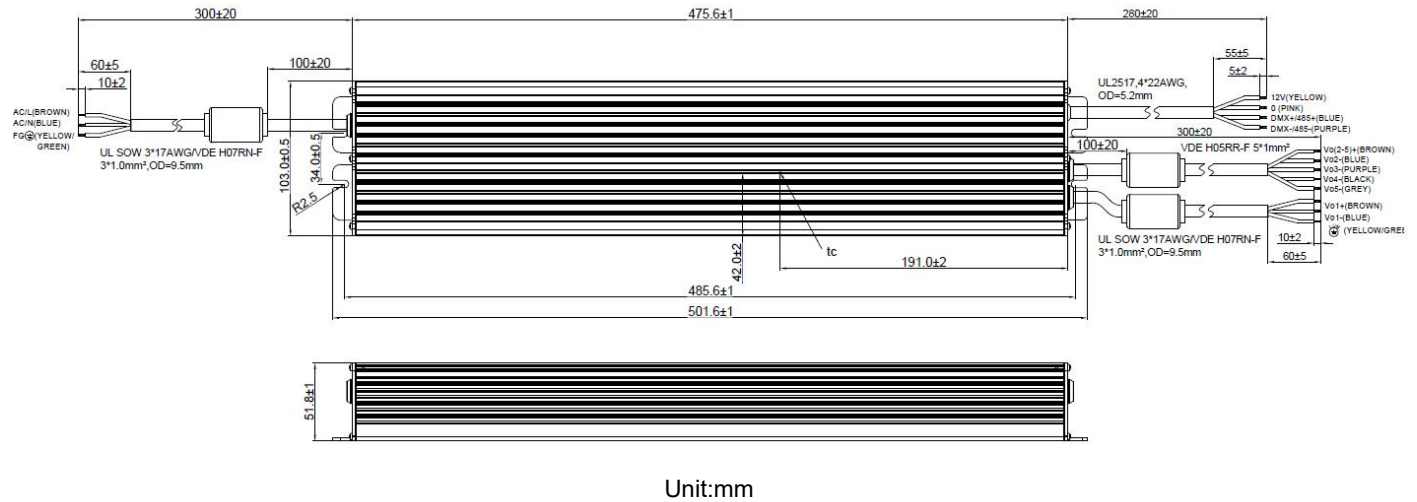

Figure 18. Mechanical Drawing

Note3: This diagram uses a 5-output channel configuration as an example—each reduction in output channels decreases one wire core in the auxiliary output.

Model	Auxiliary source wire
-DC	VED H05RR-F 2 x 1mm ² , Vo2-(BLUE)/Vo2+(BROWN)
-TC	VED H05RR-F 3 x 1mm ² , Vo2-(BLUE)/Vo3-(PURPLE)/Vo(2-3)+(BROWN)
-FC	VED H05RR-F 4 x 1mm ² , Vo2-(BLUE)/Vo3-(PURPLE)/Vo4-(BLACK)/Vo(2-4)+(BROWN)
-VC	VED H05RR-F 5 x 1mm ² , Vo2-(BLUE)/Vo3-(PURPLE)/Vo4-(BLACK)/Vo5-(GREY)/Vo(2-5)+(BROWN)

Model	Dimming wire
-UART	UL2517, 4 x 22AWG, OD=5.2mm, N/A(BLUE)/DIM+(PURPLE)/12V(YELLOW)/DIM-(PINK)
-485	UL2517, 4 x 22AWG, OD=5.2mm, 485+(BLUE)/485-(PURPLE)/12V(YELLOW)/0(PINK)
-DMX	UL2517, 4 x 22AWG, OD=5.2mm, DMX+(BLUE)/DMX-(PURPLE)/12V(YELLOW)/0(PINK)

10. Ordering information

Part Number	Rated Input AC Voltage(VAC)	Channels output	Output whether with FG line	Dimming
1600HTH320CVG-DC-485	208-480	2	With	485
1600HTH320CVG-DC-UART	208-480	2	With	UART
1600HTH320CVG-DC-DMX	208-480	2	With	DMX
1600HTH320CVG-TC-485	208-480	3	With	485
1600HTH320CVG-TC-UART	208-480	3	With	UART
1600HTH320CVG-TC-DMX	208-480	3	With	DMX
1600HTH320CVG-FC-485	208-480	4	With	485

1600HTH320CVG-FC-UART	208-480	4	With	UART
1600HTH320CVG-FC-DMX	208-480	4	With	DMX
1600HTH320CVG-VC-485	208-480	5	With	485
1600HTH320CVG-VC-UART	208-480	5	With	UART
1600HTH320CVG-VC-DMX	208-480	5	With	DMX
1600HTH400CVG-DC-485	208-480	2	With	485
1600HTH400CVG-DC-UART	208-480	2	With	UART
1600HTH400CVG-DC-DMX	208-480	2	With	DMX
1600HTH400CVG-TC-485	208-480	3	With	485
1600HTH400CVG-TC-UART	208-480	3	With	UART
1600HTH400CVG-TC-DMX	208-480	3	With	DMX
1600HTH400CVG-FC-485	208-480	4	With	485
1600HTH400CVG-FC-UART	208-480	4	With	UART
1600HTH400CVG-FC-DMX	208-480	4	With	DMX
1600HTH400CVG-VC-485	208-480	5	With	485
1600HTH400CVG-VC-UART	208-480	5	With	UART
1600HTH400CVG-VC-DMX	208-480	5	With	DMX

11.Revision History

Change Date	Rev.	Description of Change		
		Item	From	To
2025/4/23	V0.0			
2025/6/29	V0.1	Update Mechanical Specification		
		Delete -D0 model		
		No Load Output Voltage		Add max:290V(1600HTH260CV)/ 430V(1600HTH400CV)
		24V Auxiliary Output Current(-DA Model)	Max:200mA	Max:125mA
2025/9/29	V0.2	Update Mechanical Specification		

2025/10/31	V0.3	Specifications		Add 1600HTH400CVG-SC& 1600HTH260CVG-SC
		Update Mechanical Specification		
2025/11/5	V0.3	Performance Curve		Add: Total Harmonics vs Different Loads &Efficiency vs Different Loads &Power Factor vs Different Loads Modify:Input Voltage Derating Curve
		Rated Input AC Voltage		Add Notes:The upper limit voltage of CE certification:400VAC
		No Load Output Voltage	Typ:420V Max:430V	Typ:- Max:440V
		Dielectric Strength(Hi-pot)	Primary to Secondary: 3920VAC 10mA max	Primary to Output: 3600VAC 10mA max (1600HTH260CV) 3760VAC 10mA max (1600HTH400CV) Primary to Dimming: 3600VAC 10mA max (1600HTH260CV) 3760VAC 10mA max (1600HTH400CV)
			Secondary to Earth: 1550VAC 10mA max(1600HTH260CV) 1840VAC 10mA max(1600HTH400CV).	Secondary to Earth: 1550VAC 10mA max(1600HTH260CV) 1880VAC 10mA max(1600HTH400CV).
			Dimming to Output: 1550VAC 10mA max(1600HTH260CV) 1840VAC 10mA max(1600HTH400CV).	Dimming to Output: 1550VAC 10mA max(1600HTH260CV) 1880VAC 10mA max(1600HTH400CV).
2026/1/7	V0.4	Absolute Maximum Voltage on the Vdim (+) Pin	Max:15V	Max:12V
		Modify:Format		
		Model Name Definition &Output Specifications &Dimming Specifications&Mechanical Specification&Features		Delete:DA dimming
		Specifications &Output Specifications (No Load Output Voltage) &Dielectric Strength(Hi-pot)	Modify:1600HTH260CVG-SC 1600HTH400CVG-SC	Modify:1600HTH320CVG&1600HTH400CVG Delete:1600HTH260CVG Add:1600HTH320CVG-xC&1600HTH320CVG& 1600HTH400CVG
		Model Name Definition		Delete:Output without FG line
		Specifications	1600HTH260CVG Output Voltage Range:250-400V (1600HTH400CVG)	1600HTH320CVG Output Voltage Range:300-400V (1600HTH400CVG)

		Dimming Specifications		Add:RDM Protocol for the DMX model
		Performance Curve		Modify:General Performance Curve Add:Operation Range Curve
		Add:Ordering information		
		Add:Multi_channel operation principle		
		Modify:Features		
2026/3/5	V0.5	Specifications&Mechanical Specification&Ordering information		Delate:1600HTH320CVG&1600HTH400CVG
		IP Grade	IP65	IP66
		Dimming Specifications		Delete:0-10V/PWM/Rset Dimming(Single Channel)
		Performance Curve		Delete:0-10V/PWM/Rset Dimming
		Update Mechanical Specification		
		Update Derating Curve		
2026/4/9	V0.6	Performance Curve		Modify:General Performance Curve
		General Specifications		Add:Net Weight
		Modify:Features		Delete:Dimming port programming without driver power on
		EMS Standards	EN 61547	EN IEC 61547
		Modify:Features	Dimming port programming without driver power on	Dimming port programming with driver power on
		Inrush Peak Current		Add: 35A (max) &Inrush Current Curve