

800W Single Output Programmable LED Driver

800SLL系列规格书

V1.5

2023/2/18

Powerland Signatures				Customer Approval Signature
Prepared	Checked	Approved	Marketing	

Please return us one copy of the document with your approval signature.

请客户确认签字后回传我司此规格承认书。

Powerland Technology Inc.

南京博兰得电子科技有限公司

12F Building A No.6 Yongzhi Road, Qinhuai District, Nanjing, China.

南京市秦淮区永智路6号A栋12层

Email: sales@powerlandtech.com Phone: +86-25-85582306

Features

- Dimming port programming without driver power on
- CC/CV hybrid output
- High efficiency (Max 95%), active power factor correction
- Ultra low THD at light load
- Isolated 0~10V/ PWM/Rset dimming, Dim to off option
- 12V/200mA AUX Output
- UL listed with Class P
- IP65



Description

800W LED Drivers offers digital programmable drivers with wide-range adjustable output current, together with 12V/200mA auxiliary output (optional) for smart lighting.

The output current of this series are programmable, and designed for 0-10V/PWM/Rset dimming applications.

Model Name Definition

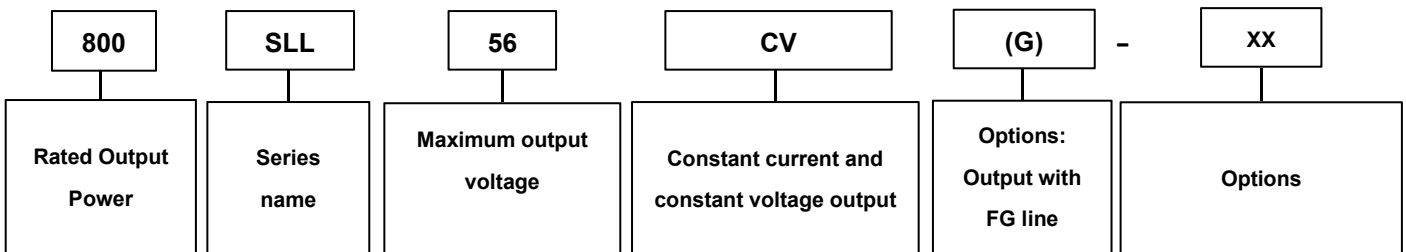

Specifications

Part Number	Max. Output Power	Programmable Current Region@CC	Output Voltage Range	Programmable Voltage Region@CV	Efficiency @277VAC
800SLL56CV(G)	800W	6.67-16.67A	28-56V	48-56 V	95%
800SLL80CV(G)	800W	4.71-11.76A	38-80V	64-80 V	95%
800SLL140CV(G)	800W	2.67-6.67A	67-140V	112-140V	95%
800SLL180CV(G)	800W	2.11-5.26A	84-180V	140-180 V	95%
800SLL240CV(G)	800W	1.57-3.92A	115-240V	192-240 V	95%

Note: Efficiency value is typical value.

Input Specifications

Parameter	Min.	Typ.	Max.	Notes
Input AC Voltage	90 Vac	-	305 Vac	
Input DC Voltage	127 Vdc	-	300 Vdc	
Input Frequency	47 Hz	-	63 Hz	
Leakage Current	-	-	0.75 mA	At 277Vac / 60Hz input , grounding effectively

Input AC Current	-	-	3.3A	Measured at full load and 277 Vac input.
	-	-	7.4A	Measured at full load and 120 Vac input.
Inrush Current	-	-	65A	At 220Vac input, 25°C cold start.
PF	0.9	-	-	At 100-277Vac, full load.
THD	-	-	20%	

Output Specifications

Parameter	Min.	Typ.	Max.	Notes
Output Current Tolerance	-5% lo set	-	5% lo set	At 25°C and full load condition
Total Output Current Ripple (pk-pk)	-	-	10% lo max	At 25°C and full load condition, 20 MHz BW
Startup Overshoot Current	-	-	20% lo max	At 25°C and full load condition
No Load Output Voltage		57		800SLL56CV(G) only
Line Regulation	-	-	±1%	Measured at full load
Load Regulation	-	-	±1%	
Turn-on Delay Time	-	0.8 s	1.5 s	Measured at 120Vac input.
Temperature Coefficient of lo set	-0.03%/°C	-	0.03%/°C	Case temperature = 0°C ~Tc max
12V Auxiliary Output Voltage	11V	12 V	15 V	
12V Auxiliary Output Source Current	0 mA	-	200 mA	Return terminal is "Dim-"
OTP Tc(Note1)	85°C	90°C	100°C	Output current will drop to 50% lowest, or shut down.
SCP				Hiccup mode, Auto recover

General Specifications

Parameter	Min.	Typ.	Max.	Notes
Standby power	-	-	1.5 W	Measured at 220Vac/50Hz; Dimming off
MTBF	-	234,000 Hours	-	Measured at 220Vac input, 80%Load and 25°C ambient temperature (MIL-HDBK- 217F)
Lifetime	-	80,000 Hours	-	Measured at 220Vac input, 80%Load and 75°C case temperature; See lifetime vs. Tc curve for the details
Operating Case Temperature Tc(Note1)	-40°C	-	90°C	
Operating Ambient Temperature Ta	-40°C	-	40°C	At 90-176Vac input
	-40°C	-	50°C	At 176-305Vac input
Storage Temperature	-40°C	-	+85°C	Humidity: 5%RH to 100%RH
Dimensions				
Inches (L × W × H)	21.50 × 1.73 × 2.17			
Millimeters (L × W × H)	546 × 44 × 55			
Net Weight	-	2.5kg	-	

Note1: There are three points could be maximum Tc point, depending on different Vac input and Vdc output. These three points (Tc, Tc1, Tc2) position are shown in below mechanical drawing.

Dimming Specifications

Parameter	Min.	Typ.	Max.	Notes
Absolute Maximum Voltage on the Vdim (+) Pin	-1 V	-	15 V	
Source Current on Vdim (+) Pin	90 uA	100 uA	110 uA	
Dimming Output Range	10% Io set	-	Io set	80% Io max ≤ Io set ≤ 100% Io max
	8% Io max	-	Io set	Io set < 80% Io max
Recommended Dimming Input Range	0 V	-	10 V	Default 0-10V dimming mode.
Dim off Voltage	0.3 V	0.5 V	0.8V	
Dim on Voltage	0.5V	0.7 V	1 V	
Hysteresis	-	0.2 V	-	
PWM_in High Level	9.8 V	10V	10.2 V	PWM is disabled default, please inform us if need this function enable.
PWM_in Low Level	-0.3 V	-	0.6 V	
PWM_in Frequency Range	200 Hz	-	3 KHz	
PWM_in Duty Cycle	1%	-	100%	
PWM Dimming off	3%	5%	7%	
PWM Dimming on	5%	7%	9%	

Safety & EMC Compliance

Safety Category	Standard
UL/CUL	UL8750,CAN/CSA-C22.2 No. 250.13-12
EMI Standards	Notes
FCC Part 15	ANSI C63.4:2009 Class B
	This device complies with Part 15 of the FCC Rules. Operation is subject to the following two conditions: (1) this device may not cause harmful interference, and (2) this device must accept any interference received, including interference that may cause undesired Operation.
EMS Standards	Notes
EN 61000-4-2	Electrostatic Discharge (ESD): 8 kV air discharge, 4 kV contact discharge
EN 61000-4-3	Radio-Frequency Electromagnetic Field Susceptibility Test-RS
EN 61000-4-4	Electrical Fast Transient / Burst-EFT: level 3, criteria A
EN 61000-4-5	Surge Immunity Test: AC Power Line: line to line 4 kV, line to earth 6 kV
EN 61000-4-6	Conducted Radio Frequency Disturbances Test-CS
EN 61000-4-8	Power Frequency Magnetic Field Test
EN 61000-4-11	Voltage Dips
EN 61547	Electromagnetic Immunity Requirements Applies To Lighting Equipment
Safety	Notes
Insulation Resistance	50Mohm min.@ primary to secondary add 500Vdc test voltage
Grounded Resistance	0.1Ω max. @ 25A, 1 minute

Isolation

Isolation	Input Wires	Output Wires	0 - 10V Wires (Class 1 & 2)	Enclosure
Input Wires	Not applicable	3750Vac	3750Vac	1800Vac
Output Wires	3750Vac	Not applicable	500Vac	1800Vac
0 - 10V Wires (Class 1 & 2)	3750Vac	500Vac	Not applicable	1800Vac
Enclosure	1800Vac	1800Vac	1800Vac	Not applicable

Performance Curve

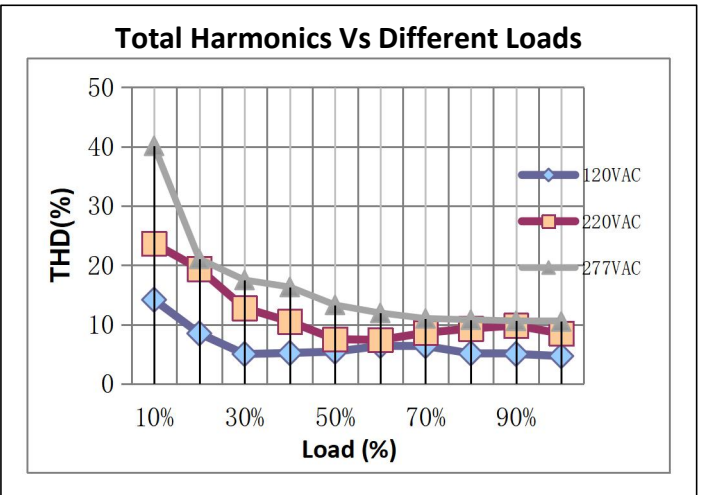
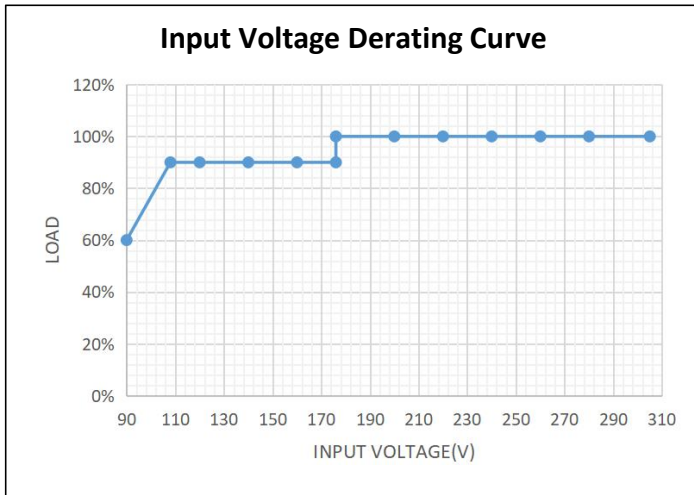

Note: If full load is required under low voltage, the lamps must cooperate with heat dissipation.

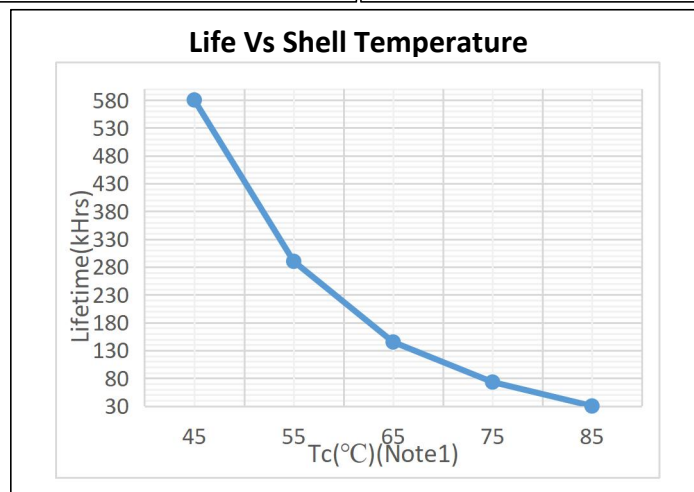
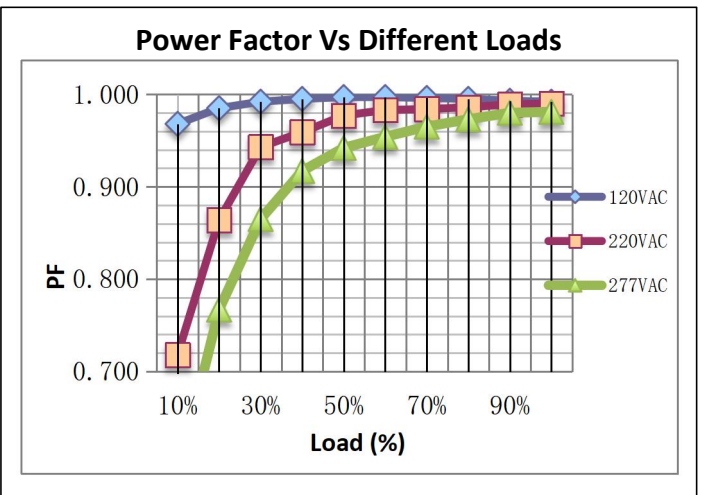
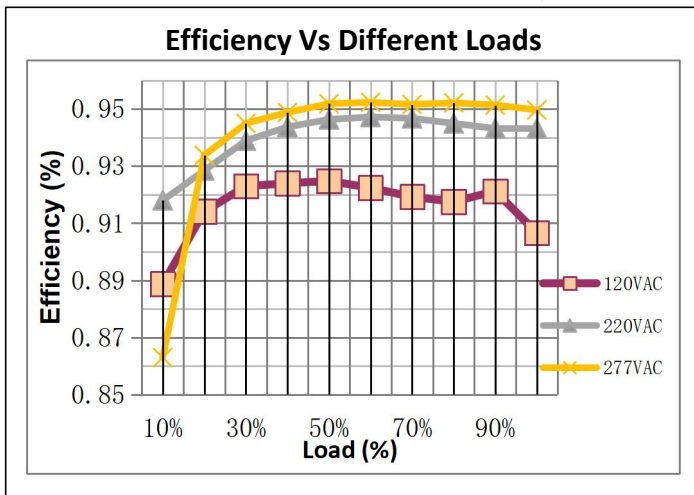

0-10V Analog Dimming & PWM Dimming

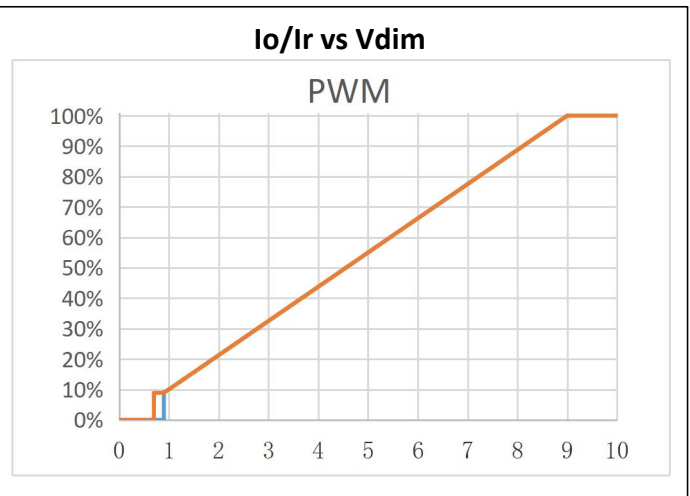
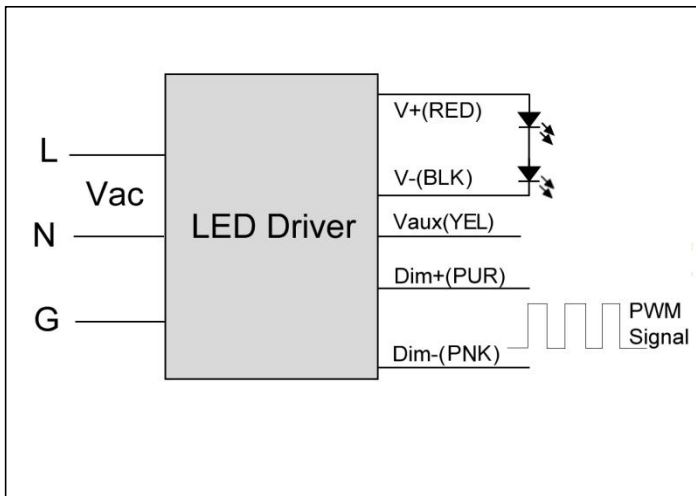
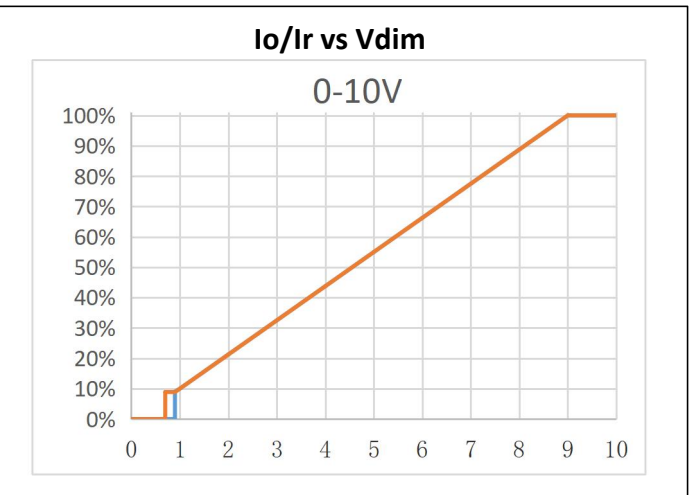
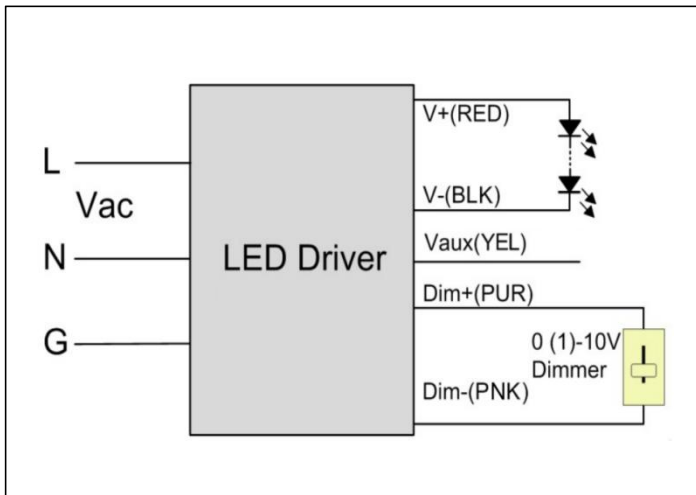

Note: The gray line in the dimming line will be changed to pink from January 1, 2022.

Programming wiring diagram

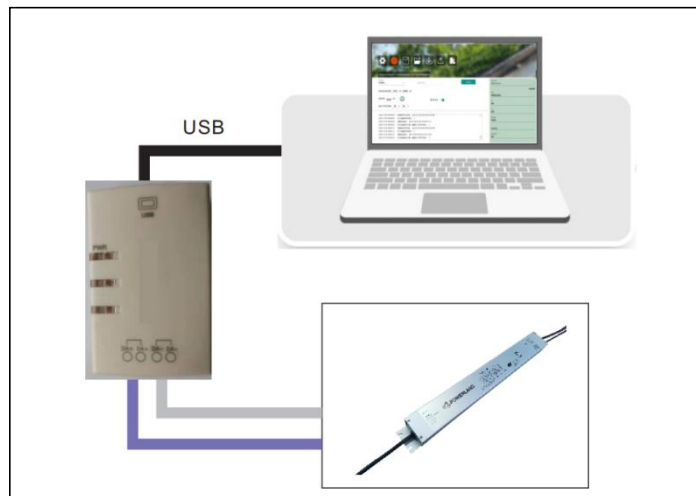

Mechanical Specification

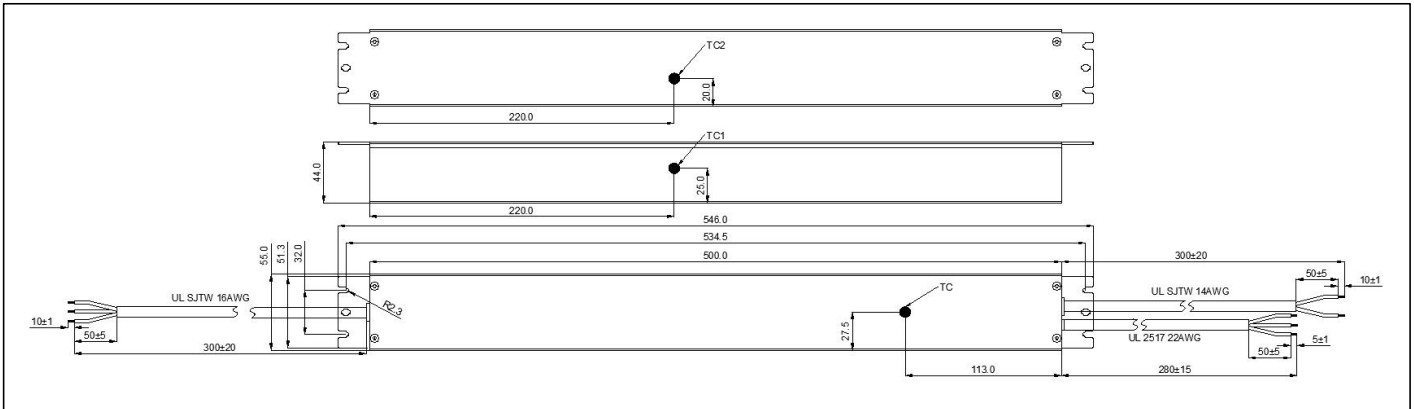

Revision History

Change Date	Rev.	Description of Change		
		Item	From	To
2021.10.9	V1.0			
2022.1.13	V1.1	Update Performance Curve		
		Update 0-10V Analog Dimming & PWM Dimming		
		Update Mechanical Drawing		
2022.1.22	V1.2	Update Input Voltage Derating Curve		
2022.3.1	V1.3	Update Performance Curve		
		Update Lifetime Curve		
		Add Isolation		
		Update Safety & EMC Compliance		Add Insulation Resistance and Grounded Resistance
2022.8.18	V1.4	Update MECHANICAL SPECIFICATION		Add TC1 and TC2
2023.2.18	V1.5	Update company logo		